



## Operations, Maintenance Manual, & Parts Bulletin 900706 Series flip stop measuring systems



**WARNING:** FOR YOUR SAFETY READ AND UNDERSTAND THIS MANUAL PRIOR TO USING THE ACCESSORY. REVIEW ALL SAFETY RULES AND OPERATING INSTRUCTIONS FREQUENTLY.

This manual is provided for your convenience in the use and care of your Original Saw Accessory. These instructions include operation, precautions, preventative maintenance and other pertinent data to assist you in assuring long life and dependable service from your measuring system.

**OS Series Sliding Flip Stop System**  
**900707 8' to 32'**  
**Measuring Systems**  
**TYPE 1**  
**Effective Date 07.01.2015**  
**MADE IN USA**

## Attaching the aluminum stop to the roller table



After the roller tables have been bolted to the saw frame using the mounting brackets, it will be time to mount the aluminum back stops. These will be mounted using the 3 included flat square threaded nuts (3 per every 8' section) and socket head cap screws and flat washers.

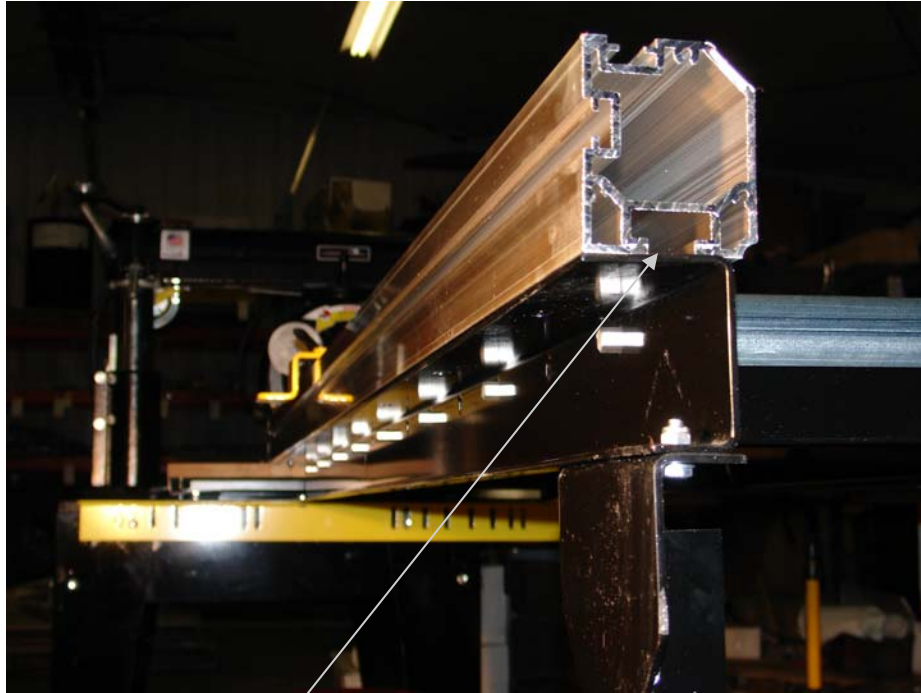

Square flat nut will insert in this T-slot on the bottom of the extrusion 3 flat nuts and 3 socket head cap screws and washers. This hardware will attach through the slotted holes in the rear (wider) flange on the roller tables

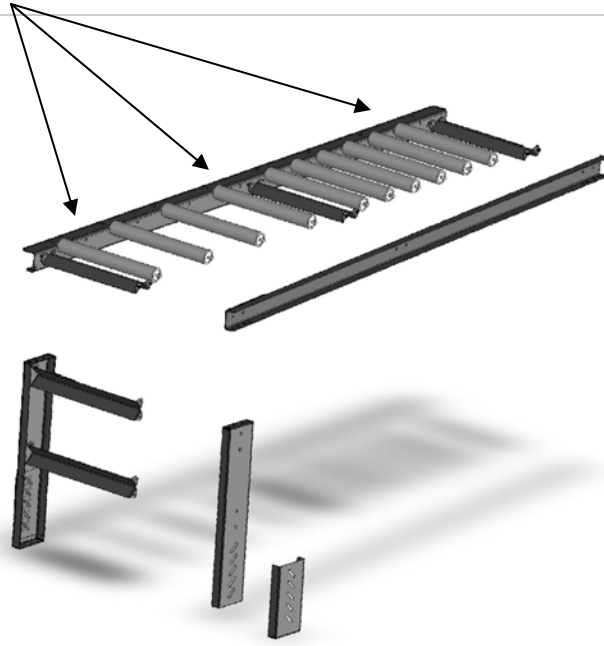

## Adjusting front extrusion sliding stops

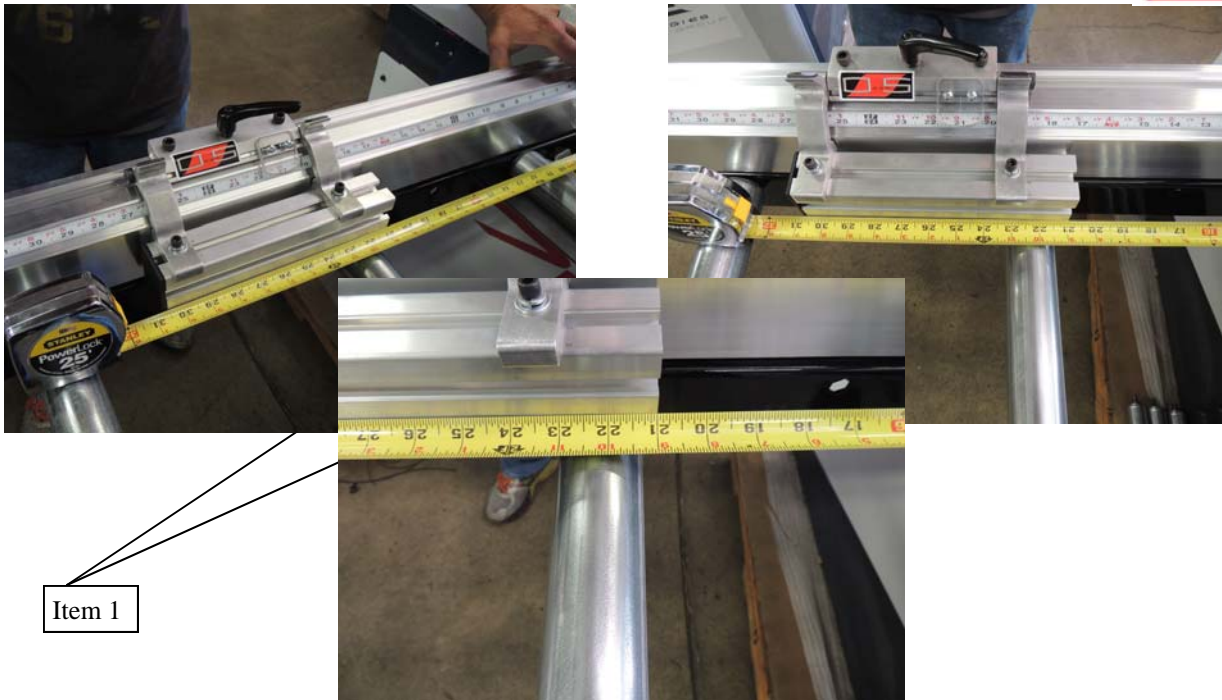

Item 1

To set the clearance between the stop and the blade simply set a tape measure against the blade and set the stop at 21" on the back stop tape. Then adjust the front extrusion to the 21" mark on the tape measure. To move the front extrusion simply loosen the socket head cap screws, (Item#1) (about 1/4—1/2 turn) and slide the extrusion., then tighten the screws once the rail is set correctly.

## Installing the end caps

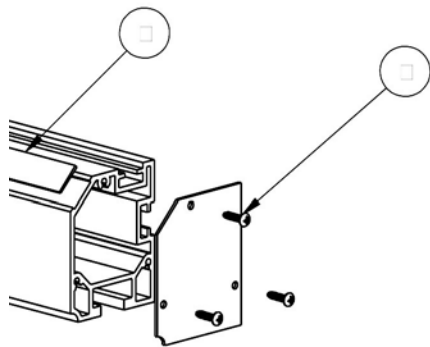

After the measuring system is installed and lined up, install the end plates, these plates will act as a stop on the outside end to keep the slider carriage from sliding off the end of the rail and will improve the looks of the assembly and keep sawdust out of the extrusion. To install simply line up the holes in the plate with the holes on the rails and attach using the 3 provided self tapping screws.



## Attaching the aluminum rails together (if included for lengths over 8'



Once the first aluminum rail is bolted to the roller table or material handling table it will be time to attach the multiple aluminum rails if they were included. This will be accomplished by sliding the rails together using the included 3/16 roll pins. The rails have already been de-burred and drilled. Simply line up the pins with the extruded holes and tap together using a board and a hammer (**note do not hammer directly on the extruded rail.**)

3/16 roll pins



Extruded holes

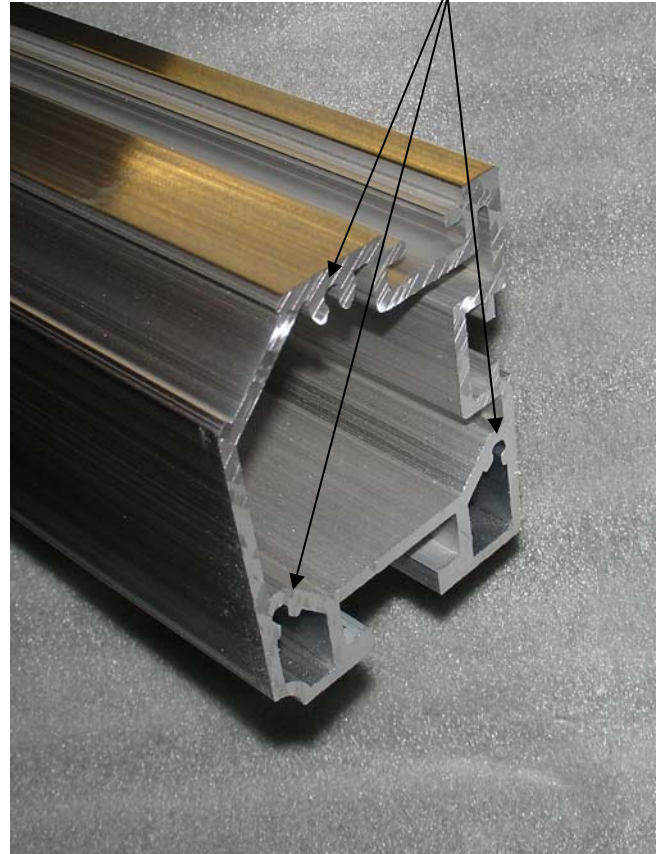

## Maintenance



From time to time the 900705 series measuring system will need to be double checked for accuracy.

Areas requiring attention will include but not be limited to:

Wear pads may need replacement depending on the frequency of use.

Indicators will need to be recalibrated

Accuracy will depend on how closely the fence is kept in its factory original position. If the fence is moved ahead or back the measuring system will not be able to measure between a straight cut and a 45° miter cut.

## Cleaning and upkeep



Weekly:

- The top portion of the extruded rail needs to be wiped off to keep the wear strips and t-nut assembly clean if buildup occurs simply wipe down with a cleaner.
- Clean out the T-slot with compressed air to keep the slot clean of foreign material that would cause undue wear on the T-nut assembly or the aluminum extrusion
- Twice yearly check to make sure the rail bolts are tight to keep the assembly rigid

# Flip Slider Assembly p/n 900721-50

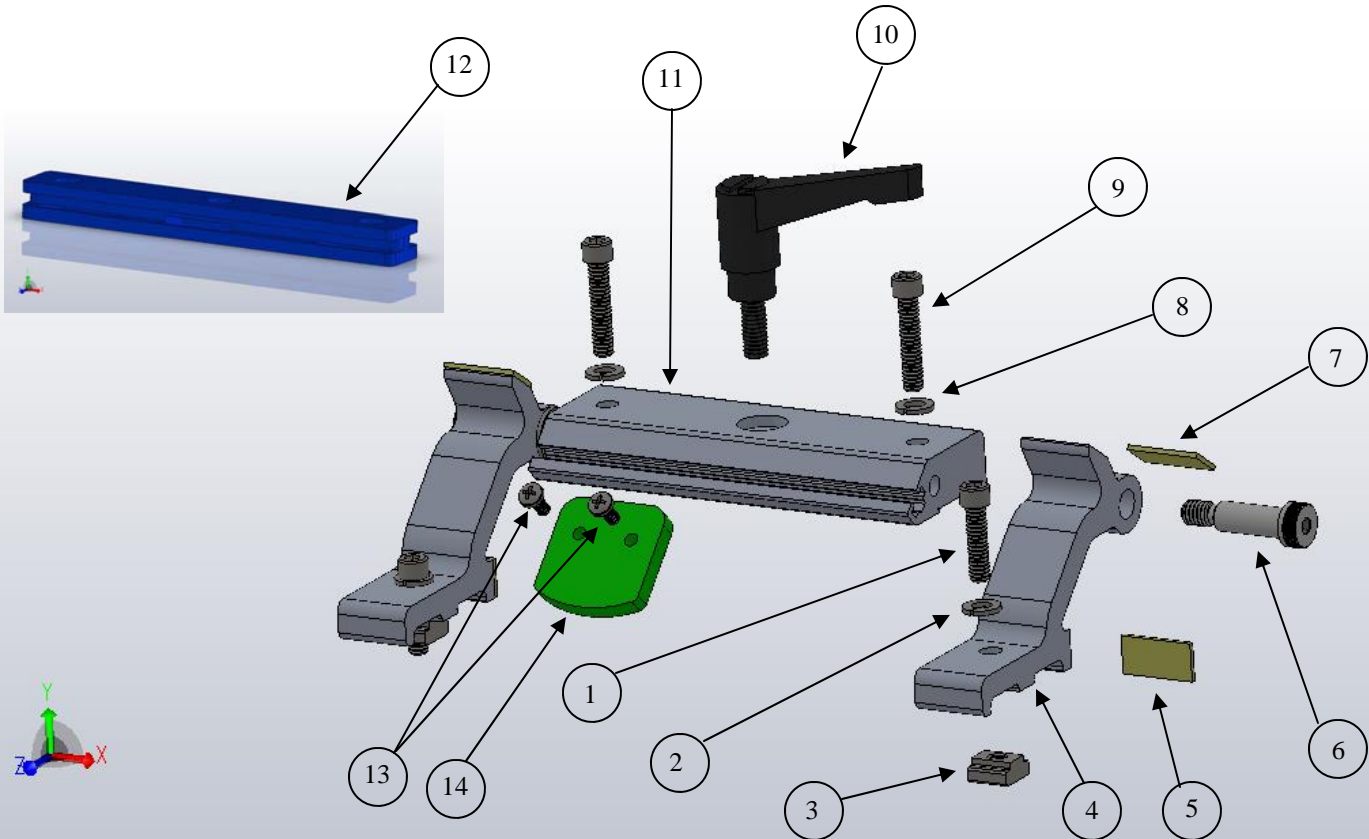

Index	Part	Description	Qty
1	082190-00	1/4-20 x 1" soc hd cap scr	2
2	084173-00	1/4" lock washer	2
3	052511-00	clamping T-nut	2
4	900760-00	arm, sliding stop	2
5	900724-50	Wear pad	4
6		Shoulder bolt	2
7	900724-50	wear pad	4
8	099384-07	1/4" lock washer	2
9	082172-00	5/16-18x1.25 soc hd cap scr	2
10	099728-13	clamp handle	1
11	900725-11	block, flip stop	1
12	900738-20	clamp nut with inserts	1
13	099262-10	#8 x 5/8 pan had screw	2
14	900723-01	lens	1
Parts not shown			
	900750-01	logo label OS Series	1

# Flip Stop complete assemblies

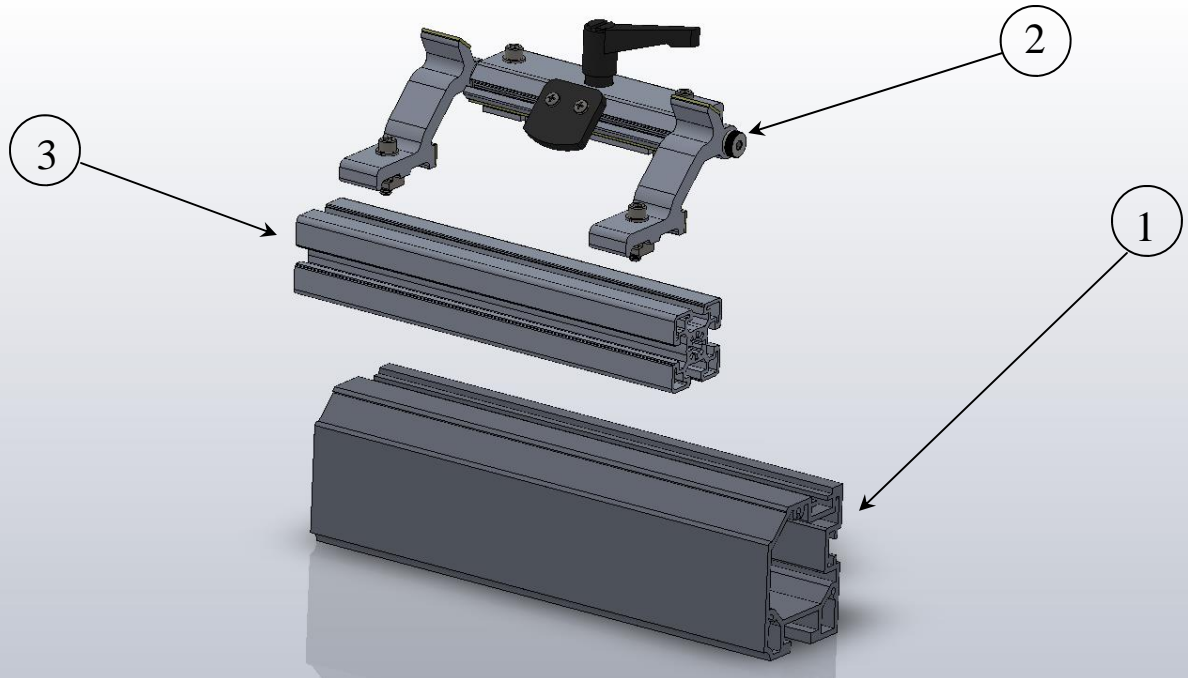

Index	Part	Description	Qty
1	180900705-00	Fence Extrusion section 8'	AR
2	900721-50	flip stop slider assy	1
3	18050100-00	Extrusion 1'	AR
		Sold in 1' increments	
Parts not show:			
	900735	clamping nut	3
	080589	socket head cap screw	3
	084173	1/4" lockwasher	3
All quantities are per 8' section of fence extrusion (for attaching #1 to extension table)			

## Industrial Use Warranty Information



Your new Original Saw Accessory is precision manufactured under strict quality standards. In the unlikely event there is trouble with your machine, the Original Saw Company warrants the unit for the period of one year from the date of purchase. The warranty covers defects in materials and workmanship. We will cover the cost of the defective part and ground shipping. If a replacement part is sent under warranty the defective part must be returned to Original Saw Company or you will be charged for the replacement. The part must also be accompanied by a return goods authorization number. This number can be obtained by calling customer service at 1-800-733-4063. When the part is returned it may be repaired or replaced at our discretion. The part must be shipped prepaid to: The Original Saw Company, Attn. Warranty Replacement Counter, 465 Third Avenue SE, Britt, Iowa 50423.

**IMPORTANT**

**IMPORTANT**

**IMPORTANT**

To assure product reliability, repairs, maintenance and adjustments should be performed by



465 Third Ave SE

P.O. Box 331

Britt, IA 50423

PH 800/733-4063 641/843-3868

FX 641/843-3869

E-mail [customerservice@originalsaw.com](mailto:customerservice@originalsaw.com)

**For parts or service please contact the manufacturer for the dealer nearest you.**

Printed in the USA © The Original Saw Company 06/15