



Original Saw Company
465 Third Ave SE
Britt, IA 50423 USA

PH 641-843-3868
800-733-4063

customerservice@originalsaw.com
www.originalsaw.com



Parts Breakdown

RADIAL ARM SAW

Woodcutting Models

TYPE 11 - without rip attachments

16" models 3551, 3556, 3571, 3576

20" models 3553, 3558

22.5" models 3554, 3559

Metal Cutting Models

16" models 3579-16M, 3579-16L

20" models 3579-*20M, 3579-20L

22.5" models 3579-22M, 3579-22L

For Serial number 20230211217 forward
(May 2023)

Made in USA

Service Record

Serial Number _____ **Date Purchased** _____

Date	Service Performed	By





POWER TOOL SAFETY

GENERAL RULES FOR SAFE OPERATION OF POWER TOOLS

1. **KNOW YOUR POWER TOOL.** Read the owner's manual carefully. Learn the applications and limitations as well as the specific potential hazards of the tool.
2. **GROUND ALL TOOLS.**
3. **KEEP GUARDS IN PLACE.** Keep guards in working order.
4. **KEEP WORK AREA CLEAN.** Cluttered areas and benches invite accidents.
5. **AVOID DANGEROUS ENVIRONMENTS.** Don't use power tools in damp or wet locations. Keep work area well lit.
6. **KEEP CHILDREN AWAY.** All visitors should keep a safe distance from the work area.
7. **DON'T FORCE TOOL.** The tool will do a better job if used at its designed rate.
8. **WEAR PROPER APPAREL.** Loose clothing, gloves or jewelry may get caught in moving parts. Rubber footwear is recommended when working outdoors.
9. **USE PROTECTIVE GLASSES.** If operation is dusty also wear a dust mask.
10. **DON'T OVER REACH.** Keep proper balance and footing at all times.
11. **MAINTAIN TOOLS WITH CARE.** Tools kept sharp and clean provide the best and safest performance. Follow instructions for lubricating and changing accessories.
12. **DISCONNECT TOOLS FROM POWER SOURCE.** When not in use, before servicing, when changing accessories, blades, or cutters, the tool should be disconnected and locked out.
13. **REMOVE ADJUSTING KEYS AND WRENCHES.** Make it a habit to ensure keys and adjusting wrenches are removed prior to starting tool.
14. **USE RECOMMENDED ACCESSORIES.** Consult your distributor or Original Saw Company for recommended accessories. Using improper accessories may cause hazards.
15. **SECURE YOUR WORK.** Use clamps or a vise to hold work when practical.
16. **NEVER LEAVE TOOL RUNNING WHILE UNATTENDED.**
17. **ONE OPERATOR ONLY.** The person who operates the saw should also position the work.
18. **DO NOT REMOVE SMALL SCRAPS FROM THE TABLE WITH YOUR FINGERS.**



CAUTION

ALL GUARDS MUST REMAIN IN PLACE FOR SAFE CUTTING OPERATON.

NOTE:

This manual is not totally comprehensive. It does not and cannot cover every possible safety and operational factor which may arise during the life of the machine.

Parts List and Ordering Instructions

Order only genuine replacement parts from your Original Saw Company Dealer.

When ordering parts be sure to include:

- Name of manufacturer—Original Saw Company
- Complete machine identification data found on name plate on front of frame
- Complete motor identification from motor name plate
- Quantity, part number and description of parts required
- Complete shipping and billing instructions

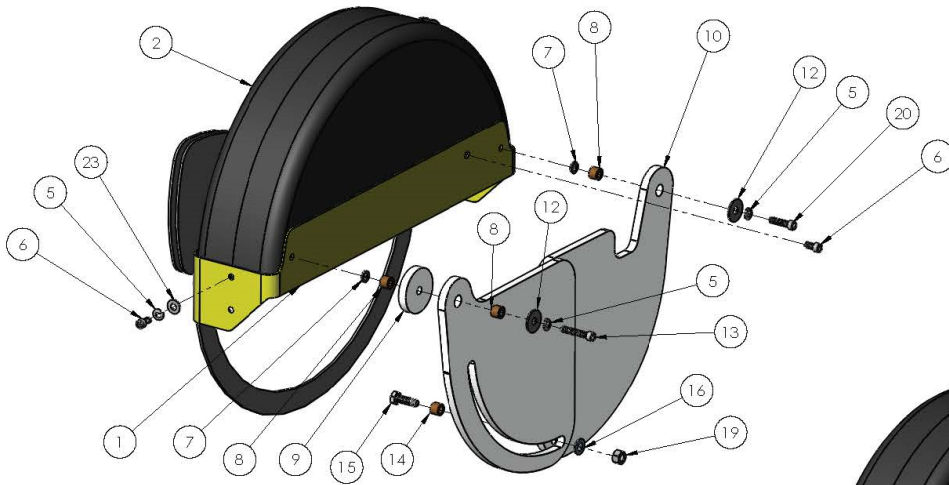

ITEM NO.	PART NUMBER	DESCRIPTION	QTY.
1	123496-04	SKIRT, BLADE GUARD 16"	1
2	123496-02	GUARD BODY, 16"	1
3	099370-04	5/16"-18 HEX NUT	2
4	046084	WASHER FLAT 1/4"	1
5	084173	Wshr. 1/4 Lock ZP	4
6	080588-00	1/4"-20 x 1/2" SHCS	3
7	096803-22	POLY WASHER, 1/4	2
8	096803-04	BUSHING, .25ID X .50OD	3
9	123496-07	GUARD BLADE SPACER 12"	1
10	123496-11	GUARD, BLADE, FRT 12"	1
11	123496-10	GUARD, BLADE, REAR 12"	1
12	080457	Flat Washer 1/4 x 1" zinc	2
13	0996154-22	1/4-20X13/8 SHCS	1
14	096803-02	5/16" BRASS BUSHING	1
15	082104-02	5/16"-18 x 1 1/4" HEX BOLT	1
16	099361-16	5/16" FLAT WASHER	1
17	123494-00	16" Lower Guard Ring	1
18	099364-04	5/16"-18 HEX NUT	4
19	082024-02	Nut, 5/16-18 Elastic Stop ZP	1
20	082190	Scr 1/4-20x1 SHCS Black	1
21	123493-00	16" Guard Retainer	4
22	096694	Guard Mount Bracket	1
23	046084	WASHER FLAT 1/4"	1
24	099384-07	5/16" LOCK WASHER	2

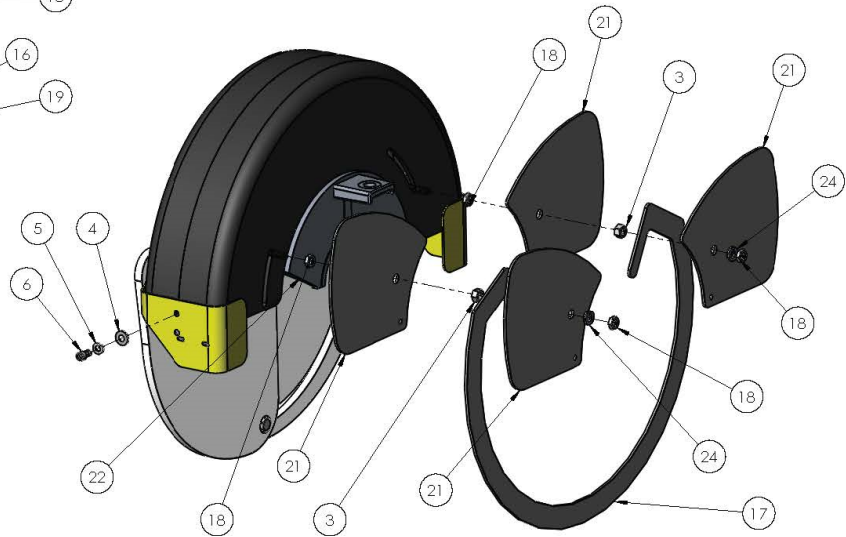

035016-10

Parts List and Ordering Instructions

Order only genuine replacement parts from your Original Saw Company Dealer.

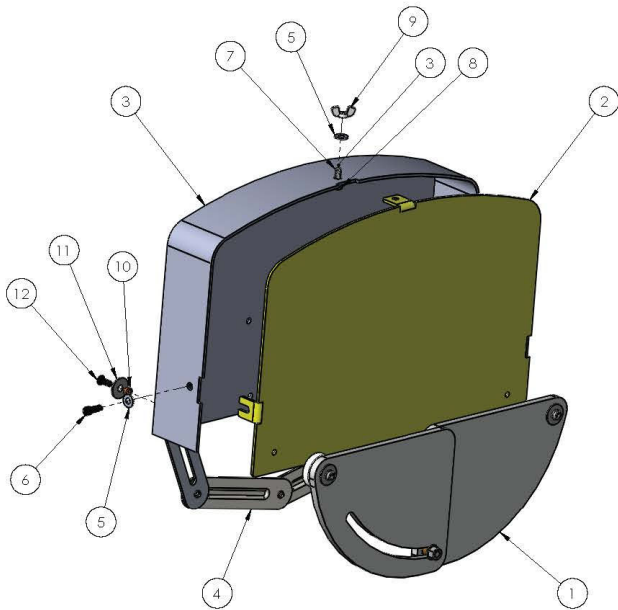

ITEM NO.	PART NUMBER	DESCRIPTION	QTY.
1	090531-12	Lower Guard Assembly 16" MC	1
2	090530-01	GUARD-DOOR, 16"	1
3	090530-00	GUARD ASSEMBLY, 16"	1
4	096805	16" Link Set	1
5	046084-00	1/4" FLAT WASHER	3
6	080589	SHCS, 1/4-20 X .75	2
7	082398	Scr 1/4-20 x 1 SSSCPPT Black	1
8	038738	NUT HEX 1/4-20	1
9	037667	WING NUT, 1/4-20	1
10	096803-00	SPACER	2
11	080457	Flat Washer 1/4 x 1" zinc	2
12	052511	1/4-20 x 5/8 Screw	2

Note : 096805 16" link set includes item # 4,10,11,12

090531-16

16" Guard Assembly, Complete, no rip attachments

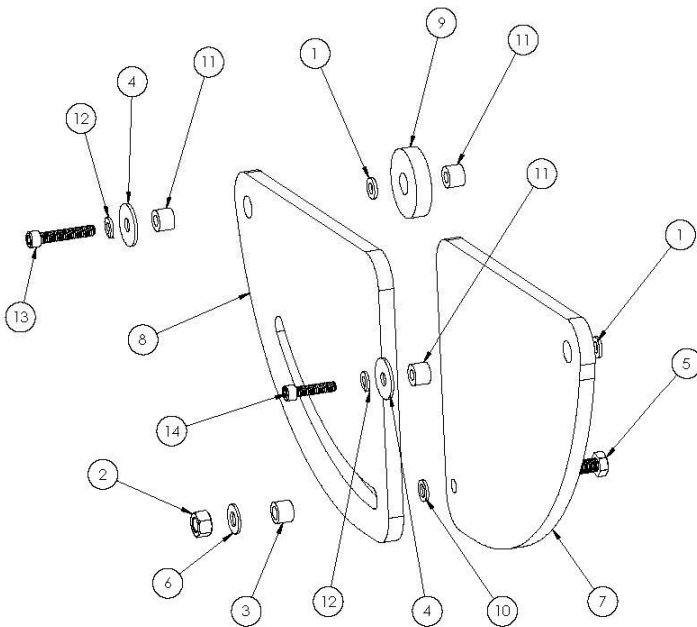

ITEM NO.	PART NUMBER	DESCRIPTION	QTY.
1	096803-22	POLY WASHER, 1/4	2
2	082024-02	Nut, 5/16-18 Elastic Stop ZP	1
3	096803-02	5/16" BRASS BUSHING	1
4	080457	Flat Washer 1/4 x 1" zinc	2
5	082104-02	5/16"-18 x 1" HEX BOLT	1
6	099361-16	5/16" FLAT WASHER	1
7	090531-11	Guard Blade Front 16" HDPE MC	1
8	090531-10	Guard Blade Rear 16" HDPE MC	1
9	090531-07	GUARD BLADE SPACER 16" MC	1
10	096803-20	5/16" PLASTIC WASHER	1
11	096803-04	BUSHING, .25ID X .50OD	3
12	084173	Wshr. 1/4 Lock ZP	2
13	099154-22	1/4-20X13/8 SHCS	1
14	082190	Scr 1/4-20 x 1 SHCS Black	1

090531-12

Lower plastic guard assembly 16"
For steel fabricated guards

Parts List and Ordering Instructions

Order only genuine replacement parts from your Original Saw Company Dealer.

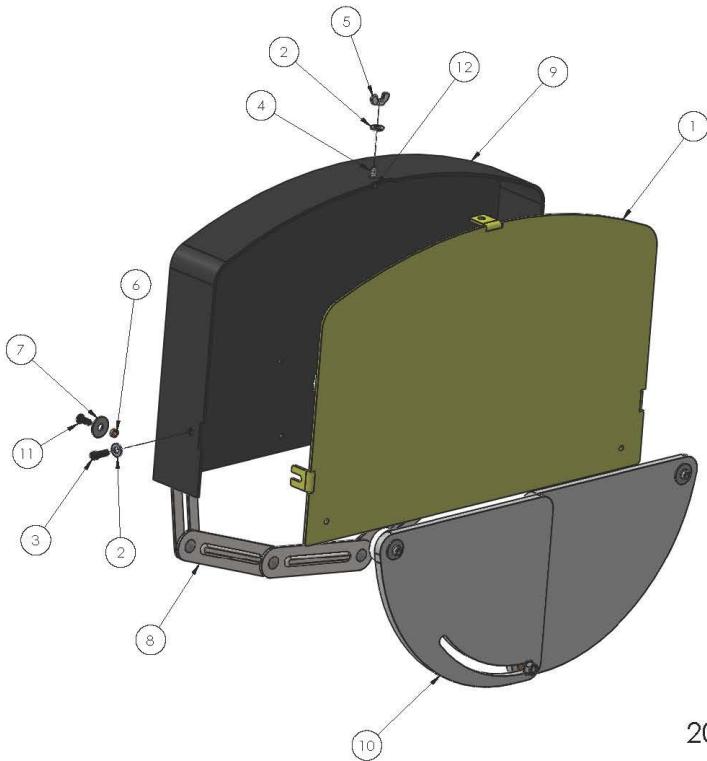

ITEM NO.	PART NUMBER	DESCRIPTION	QTY.
1	090534-01	GUARD-DOOR, 20"	1
2	046084-00	1/4" FLAT WASHER	3
3	080589	SHCS, 1/4-20 X .75	2
4	082398	Scr 1/4-20 x1 SSSCPPT Black	1
5	037667	WING NUT, 1/4-20	1
6	096803-00	SPACER	2
7	080457	Flat Washer 1/4 x 1" zinc	2
8	096675	20" Link Set	1
9	090534-00	Guard 20" Rear Assembly	1
10	090533-12	Lower Guard Assembly 20" MC	1
11	052511	1/4-20 x 5/8 Screw	2
12	038738	NUT HEX 1/4-20	1

Note : 096675 20-22" link set includes item # 8,6,7,11

090533-20

20" Guard Assembly, Complete, no rip attachments

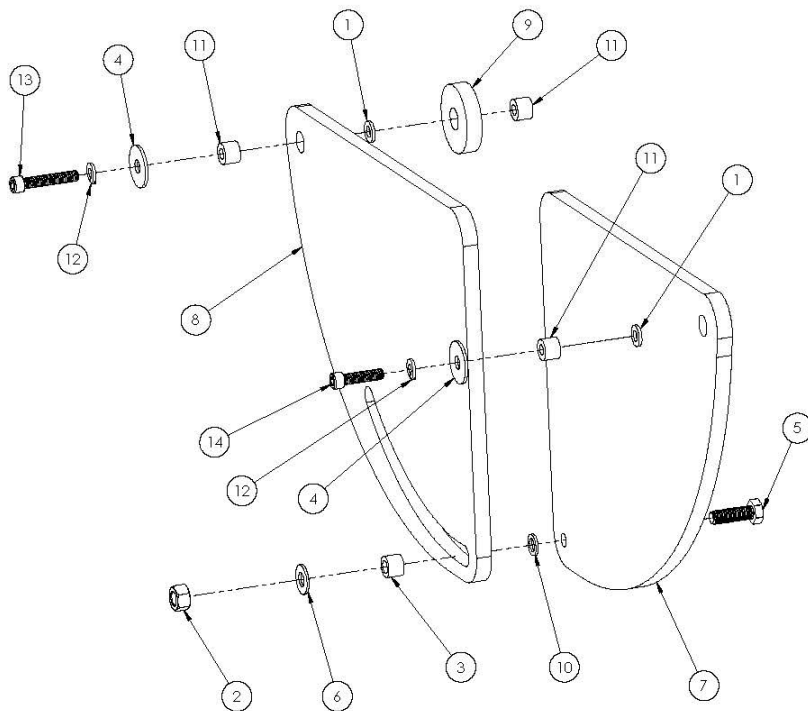

ITEM NO.	PART NUMBER	DESCRIPTION	QTY.
1	096803-22	POLY WASHER, 1/4	2
2	082024-02	Nut, 5/16-18 Elastic Stop ZP	1
3	096803-02	5/16" BRASS BUSHING	1
4	080457	Flat Washer 1/4 x 1" zinc	2
5	082104-02	5/16"-18 x 1" HEX BOLT	1
6	099361-16	5/16" FLAT WASHER	1
7	090533-11	Guard Blade Front 20" HDPE MC	1
8	090533-10	Guard Blade Rear 20" HDPE MC	1
9	090531-07	GUARD BLADE SPACER 16" MC	1
10	096803-20	5/16" PLASTIC WASHER	1
11	096803-04	BUSHING, .25ID X .50OD	3
12	084173	Wshr. 1/4 Lock ZP	2
13	099154-22	1/4-20X13/8 SHCS	1
14	082190	Scr 1/4-20 x1 SHCS Black	1

090533-12

Lower plastic guard assembly 20"
For steel fabricated guards

Parts List and Ordering Instructions

Order only genuine replacement parts from your Original Saw Company Dealer.

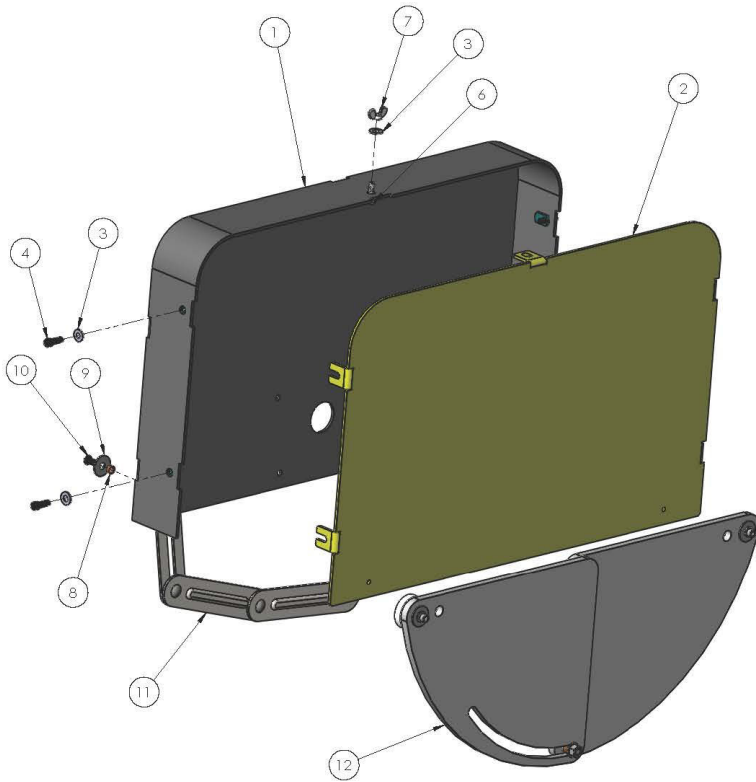

ITEM NO.	PART NUMBER	DESCRIPTION	QTY.
1	090535-00	Guard Section, 22"	1
2	090535-01	Guard door, 22"	1
3	046084-00	1/4" FLAT WASHER	5
4	080589	SHCS, 1/4-20 X .75	4
5	082398	Scr 1/4-20 x 1 SSSCPPT Black	1
6	038738	NUT HEX 1/4-20	1
7	037667	WING NUT, 1/4-20	1
8	096803-00	SPACER	2
9	080457	Flat Washer 1/4 x 1" zinc	2
10	052511	1/4-20 x 5/8 Screw	2
11	096675	20"-22" Link Set	1
12	090535-12	Lower Guard Assembly 20" MC	1

Note : 096675 20-22" link set includes item # 11,8,9,10

090535-22

22" Guard Assembly, Complete, no rip attachments

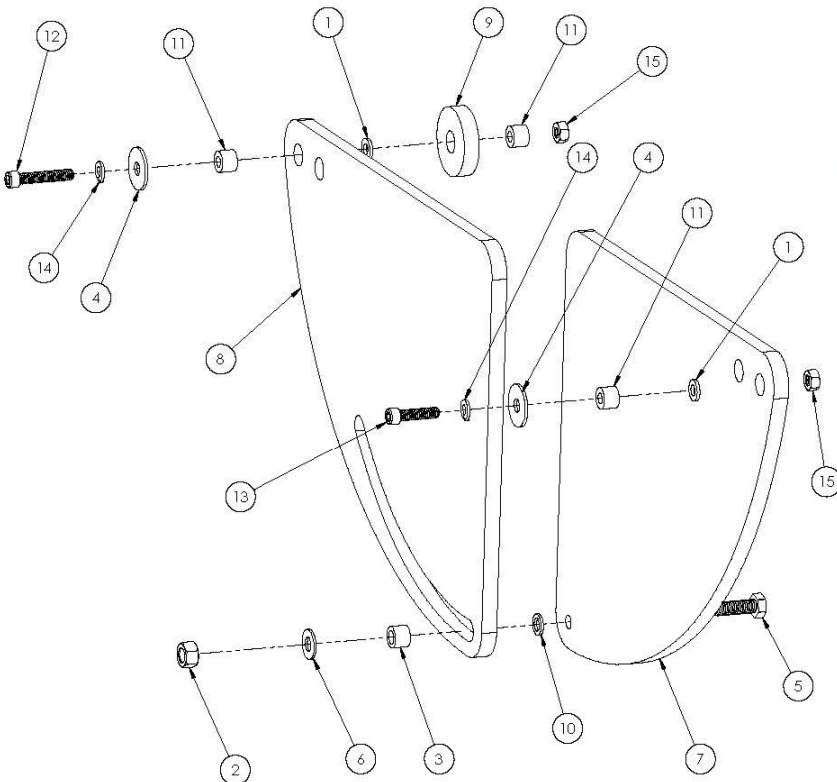

ITEM NO.	PART NUMBER	DESCRIPTION	QTY.
1	096803-22	POLY WASHER, 1/4	2
2	082024-02	Nut, 5/16-18 Elastic Stop ZP	1
3	096803-02	5/16" BRASS BUSHING	1
4	080457	Flat Washer 1/4 x 1" zinc	2
5	082104-02	5/16"-18 x 1" HEX BOLT	1
6	099361-16	5/16" FLAT WASHER	1
7	090535-11	Guard Blade Front 22" HDPE MC	1
8	090535-10	Guard Blade Rear 22" HDPE MC	1
9	090531-07	GUARD BLADE SPACER 1/6" MC	1
10	096803-20	5/16" PLASTIC WASHER	1
11	096803-04	BUSHING, .25ID X .50OD	3
12	099154-22	1/4-20X13/8 SHCS	1
13	082190	Scr 1/4-20 x 1 SHCS Black	1
14	084173	Wshr. 1/4 Lock ZP	2
15	099374-07	REV NUT, 1/4-20	2

090535-12

Lower plastic guard assembly 22"
For steel fabricated guards

Parts List and Ordering Instructions

Order only genuine replacement parts from your Original Saw Company Dealer.

When ordering parts be sure to include:

- Name of manufacturer—Original Saw Company
- Complete machine identification data found on name plate on front of frame
- Complete motor identification from motor name plate
- Quantity, part number and description of parts required
- Complete shipping and billing instructions

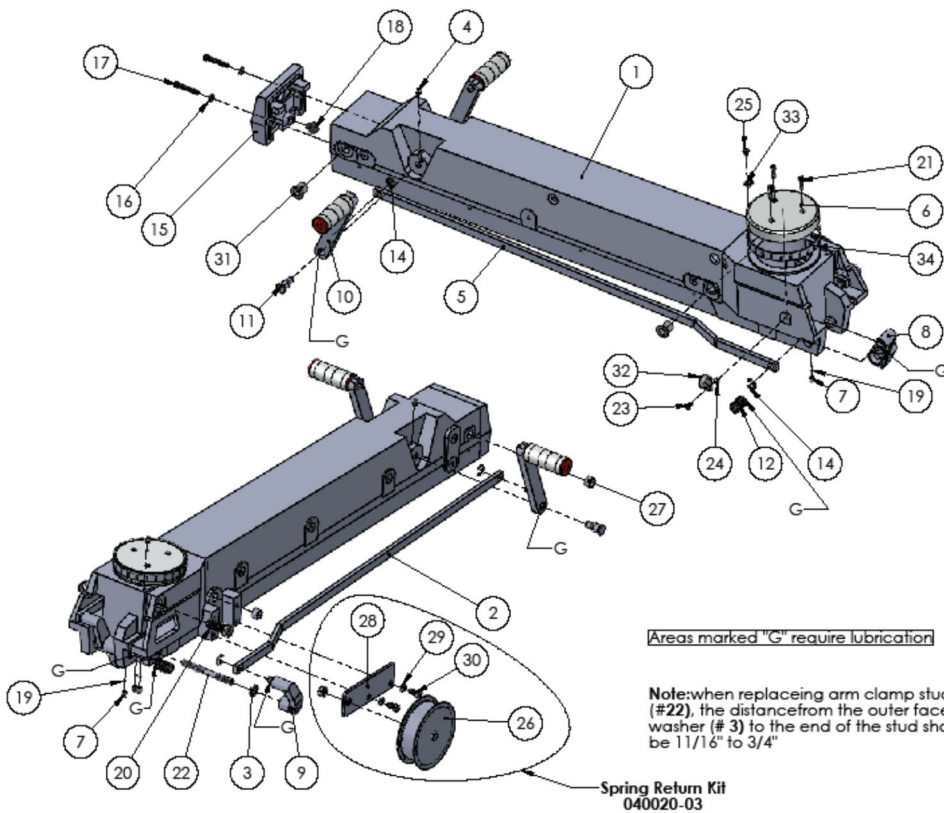

ITEM NO.	PART NUMBER	DESCRIPTION	QTY.
1	68545-00	Arm (44")	1
1A	068545-01	Arm (52")	1
2	068189-01	44" Miter Clamp Bar	1
2A	068189-02	Miter Clamp (52")	1
3	122051	Flat Washer	1
4	068703	5/16-18 x 1/2 set Screw	3
5	068188-01	44" Miter Latch Bar	1
5A	068188-02	Miter Latch (52")	1
6	122458-03	Miter Cap	1
7	068967	3/8-16 x 1/2 Set Screw	4
8	068590	Miter Latch	1
9	068591	Miter Clamp	1
10	068589-04	Miter Handle	2
11	116406	Bearing Shaft - Concentric	2
12	068262	Adjustment Screw	2
14	058529	Retaining Ring	4
15	068190-04	End Cap	1
16	099384-07	5/16" LOCK WASHER	2
17	082179	5/16-18 X 2" SHCS	2
18	070871	End Cap Bumper	1
19	083412	1/4" Set Screw Slug	5
20	082115	5/8-11x3/4 Hexhd Cap Screw	1
21	082190	Scr 1/4-20 x 1 SHCS Black	3
22	068424	Stud	1
23	080634	1/4-12x1/2 rhd Screw	1
24	084173	Wshr. 1/4 Lock ZP	1
25	099264-06	1/4-20 x 3/8 Panhd Screw	1
26	066212-00	Spring Return	1
27	068955	Sleeve Bearing	2
28	084963-01	MOUNT BRACKET, RETURN	1
29	000415	LOCK WASHER, 3/8	2
30	082098	3/8-16x3/4 Hexhead Bolt	2
31	070258	Flanged Bushing	2
32	081778	Cable Clamp	1
33	203597-09	Miter Pointer	1
34	068567	Miter Scale	1



44" Arm Assem 52" Arm Assem
800410 800420-02

Parts List and Ordering Instructions

Order only genuine replacement parts from your Original Saw Company Dealer.

When ordering parts be sure to include:

- Name of manufacturer—Original Saw Company
- Complete machine identification data found on name plate on front of frame
- Complete motor identification from motor name plate
- Quantity, part number and description of parts required
- Complete shipping and billing instructions

ITEM NO.	PART NUMBER	DESCRIPTION	QTY.
1	068632	ROLLER HEAD, SD	1
2	068636	Rp lock	1
3	068654-09	Knob and stud assy - adj arm stop	1
4	103422	Bearing Shaft Washer	8
5	081476-01	Bearing	8
6	116406	Bearing Shaft - Concentric	6
7	096770	Bearing Shaft - Eccentric	2
8	070269	Bevel Stop Lock	1
9	067927	KING BOLT	1
10	68635	Shoe	1
11	068263	Bevel Stop Rod	1
12	070270	Stop Plate	1
13	099358-08	Flat Washer	1
14	080590	SHCS, 5/16-18 X 1.75	1
15	058529	Retaining Ring	1
16	068703	5/16-18 x 1/2 set Screw	8
17	068653	Bumper	1
18	099264-06	1/4-20 x 3/8 Panhd Screw	2

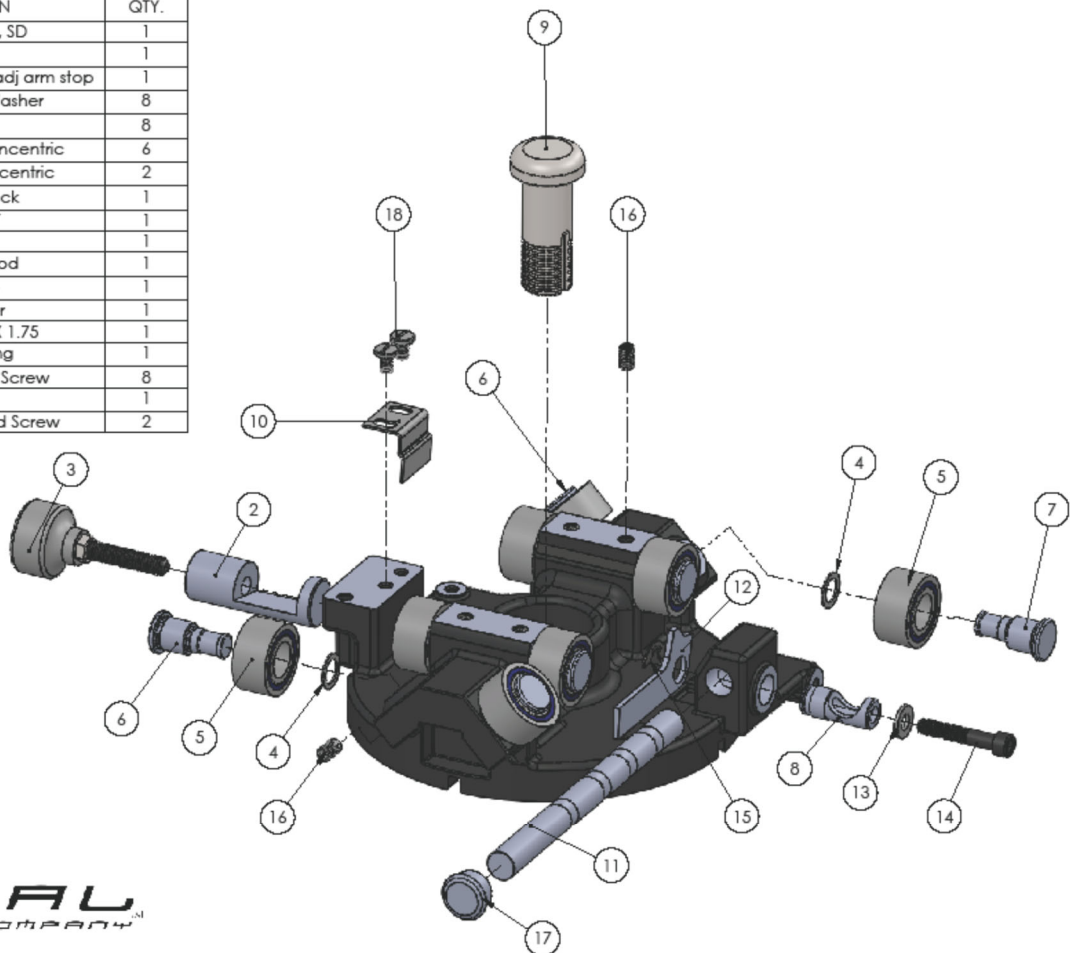

**Roller Head
800500-02**



Parts List and Ordering Instructions

Order only genuine replacement parts from your Original Saw Company Dealer.

When ordering parts be sure to include:

- Name of manufacturer—Original Saw Company
- Complete machine identification data found on name plate on front of frame
- Complete motor identification from motor name plate
- Quantity, part number and description of parts required
- Complete shipping and billing instructions

ITEM NO.	PART NUMBER	DESCRIPTION	QTY.
1	068622	Yoke	1
2	068627-01	Swivel Latch Handle	1
3	068626	Adjusting Screw	4
4	083412	1/4" Set Screw Slug	6
5	068703	5/16"-18 x 1/2 set Screw	6
6	068628-01	Bevel Lach Handle	1
7	068625	Stud	1
8	046084-00	1/4" FLAT WASHER	1
9	068629-01	Bevel Clamp Handle	1
10	068623	Front Trunion	1
11	082172-00	5/16"-18 x 1 1/4" SHCS	1
12	082168-00	5/16"-18 x 1" SHCS	8
13	068624	Rear Trunion	1
14	203085	Special Washer	4
15	068631	Dowel Screw	1
16	073872	Bevel Scale	1
17	099264-06	1/4-20 x 3/8 Panhd Screw	4
18	203588-01	Pointer	1
19	084173	Wshr. 1/4 Lock ZP	1
20	082200	Scr 5/16 x 3/8 SHCS Black	1
21	068655	Adjuster Washer	1
22	096775	Yoke Clamp Handle	1
23	090539	HEX JAM NUT, 1.00-14	1

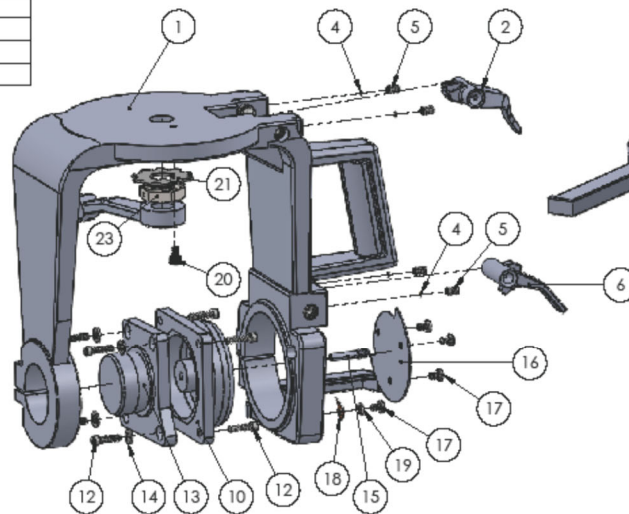
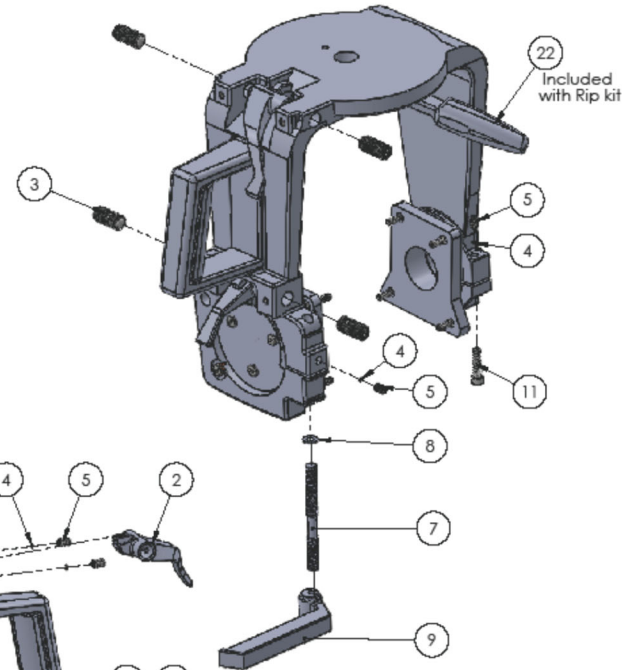

**Yoke and Trunion Assem
800300-01**



ly.

Parts List and Ordering Instructions

Order only genuine replacement parts from your Original Saw Company Dealer.

When ordering parts be sure to include:

- Name of manufacturer—Original Saw Company
- Complete machine identification data found on name plate on front of frame
- Complete motor identification from motor name plate
- Quantity, part number and description of parts required
- Complete shipping and billing instructions

ITEM NO.	PART NUMBER	DESCRIPTION	QTY.
1	068649-00	Column Base	1
2	068955	Sleeve Bearing	1
3	073878	Column	1
4	099187-56	1/2-13 x 3 1/2 Hexhd Cap Screw	1
5	068651	1/2-13 x 2 Set Screw	2
6	081959	1/2-13 Hex Nut	1
7	081960	1/4"-20 HEX JAM NUT	2
8	082525	5/8 Star Washer	2
9	099159-36	5/8-11 x 2 1/4 Hexhd Cap Screw	2
10	080682	5/8 Lock Washer	4
11	099159-24	5/8-11 x 1 1/2 Hexhd Cap Screw	2
12	068646	Column Insert	1
13	068641	Elevating Screw	1
14	068642-01	Elevating Nut	1
15	039746	LOCATING PIN, 1/4	1
16	063564	Bearing	1
17	068647	Thrust Washer	1
18	061382	Bevel Gear Set	1
19	088171	Key	1
20	082205	SHCS 5/16-18 X 5/8	5
21	099022-04	Retaining ring	2
22	068643	Clamp Screw	1
23	068824	Lock Screw	1
24	122051	Flat Washer	1
25	068648-01	Clamp Handle	1
26	068644	Gib	1

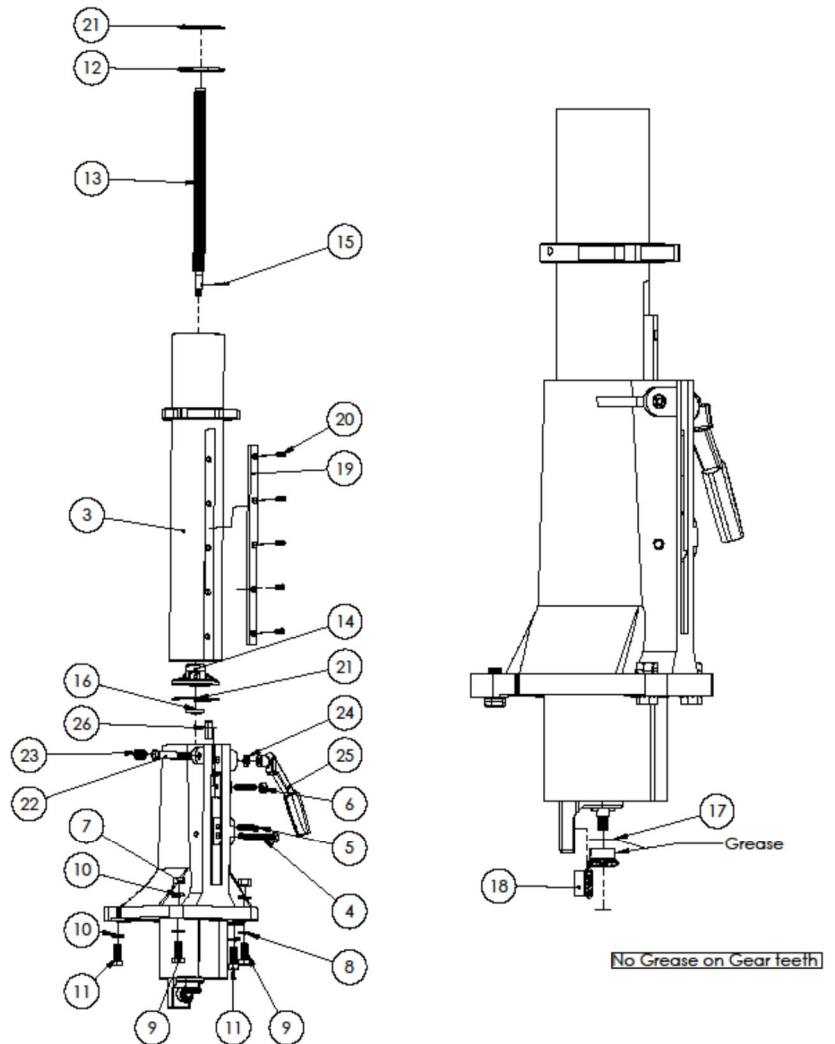

Base and Column Assem 800200-02



Parts List and Ordering Instructions

Order only genuine replacement parts from your Original Saw Company Dealer.

When ordering parts be sure to include:

- Name of manufacturer—Original Saw Company
- Complete machine identification data found on name plate on front of frame
- Complete motor identification from motor name plate
- Quantity, part number and description of parts required
- Complete shipping and billing instructions

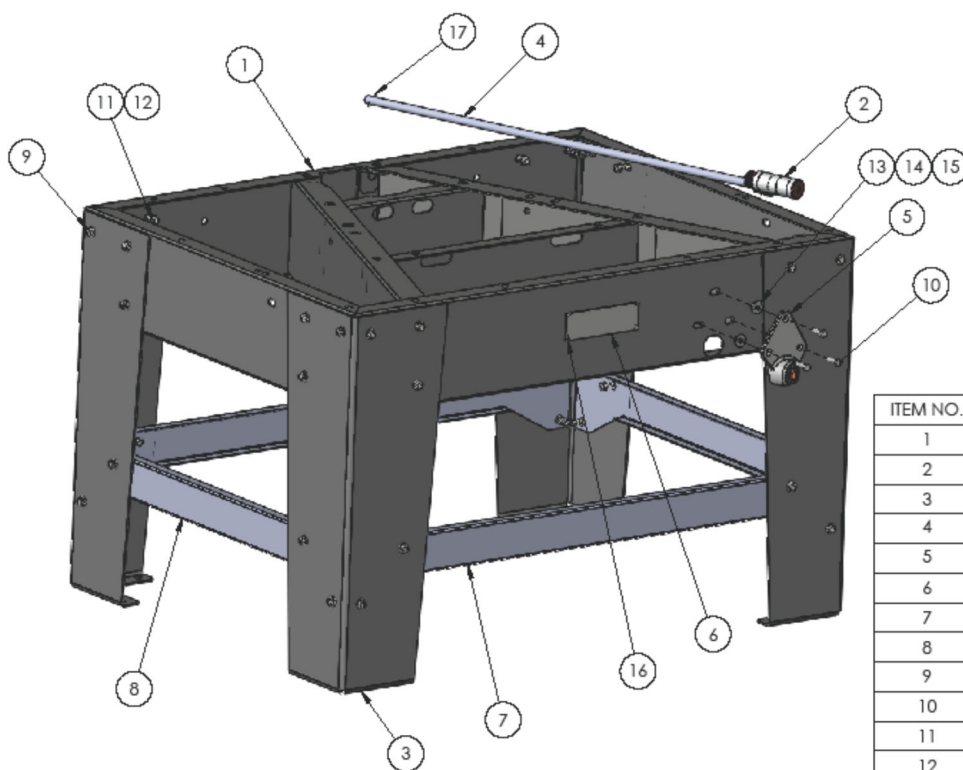

ITEM NO.	PART NUMBER	DESCRIPTION	QTY.
1	068659-01	FRAME ASM-SAW, SD	1
2	070964-03	CRANK HANDLE ASM	1
3	083165-01	SD TABLE LEG	4
4	068670-02	Elevating Shaft 39"	1
5	068708-01	Elevating Bracket	1
6	123459-01	Machine Name Plate	1
7	083165-11	SUPPORT LEG, SAW . LONG	2
8	083165-13	SUPPORT LEG, SAW, SHORT	2
9	082102	HEX FLANGE BOLT, 3/8-13 X .75	40
10	082104	5/16"-18 x 1 1/4" HEX BOLT	3
11	084180-00	3/8-16 Hex Nut	40
12	000415	LOCK WASHER, 3/8	40
13	099361-18	Flat Washer 5/16 x 1" zinc	3
14	099384-07	5/16" LOCK WASHER	3
15	08028-02	5/16-18 Hex Nut ZP	3
16	012122	DRIVE SCREW	4
17	039746	LOCATING PIN, 1/4	1

**800122-03
SD Frame Assy**



Parts List and Ordering Instructions

Order only genuine replacement parts from your Original Saw Company Dealer.

When ordering parts be sure to include:

- Name of manufacturer—Original Saw Company
- Complete machine identification data found on name plate on front of frame
- Complete motor identification from motor name plate
- Quantity, part number and description of parts required
- Complete shipping and billing instructions

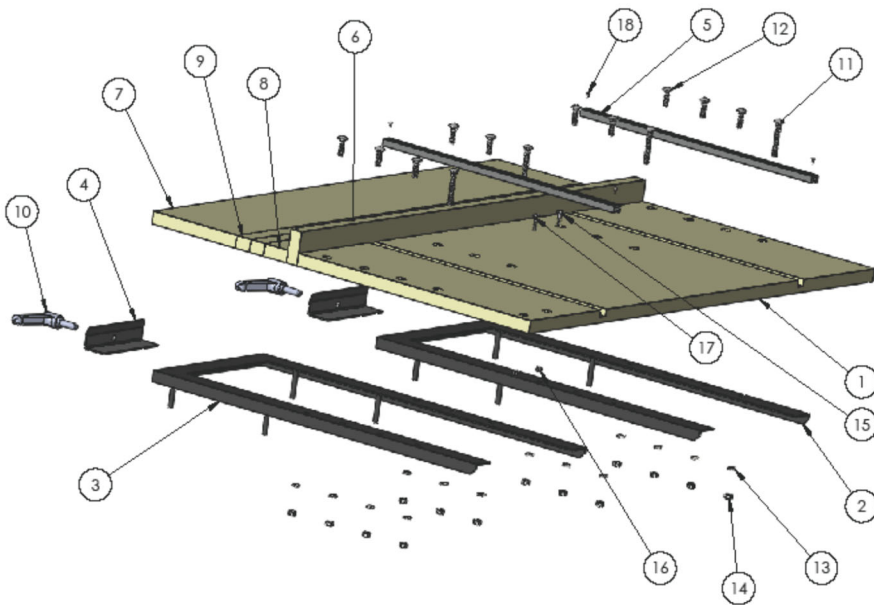

ITEM NO.	PART NUMBER	DESCRIPTION	QTY.
1	090516-04	SD Front Table Board, 25 x 49 Drilled and Slotted	1
2	090514-01	Cleat, Table 20"/16" Wood cutting	1
3	090515-01	Cleat, Table 20"/16" Wood cutting	1
4	068666-05	CLAMP, TABLE	2
5	050116-635	T-slot 25"	2
6	103721	3 x 49	1
7	068663-04	Spacer Board 9 x 49	1
8	090517	2.5 x 49	1
9	068664-01	Spacer Board 1.5 x 49	2
10	068706	Knob;Clamping ratchet 1/2"	2
11	068821	Scr.3/8-16x3 Rd.Hd.Mach.	4
12	068822	Scr.3/8-16x1 1/2 Rd.Hd.Mach.	10
13	000415	LOCK WASHER, 3/8	14
14	084180-00	3/8-16 Hex Nut	14
15	046084-00	1/4" FLAT WASHER	2
16	082024-00	1/4"-20 LOCK NUT	2
17	082023-04	1/4-20 x 1 1/4	2
18	083371-12	Screw, 10 x 1/2 sheet metal screw	4

800150-02

SD 16"/ 20" MDF Table Assy Med Arm with countersunk t-slot rail

Parts List and Ordering Instructions

Order only genuine replacement parts from your Original Saw Company Dealer.

When ordering parts be sure to include:

- Name of manufacturer—Original Saw Company
- Complete machine identification data found on name plate on front of frame
- Complete motor identification from motor name plate
- Quantity, part number and description of parts required
- Complete shipping and billing instructions

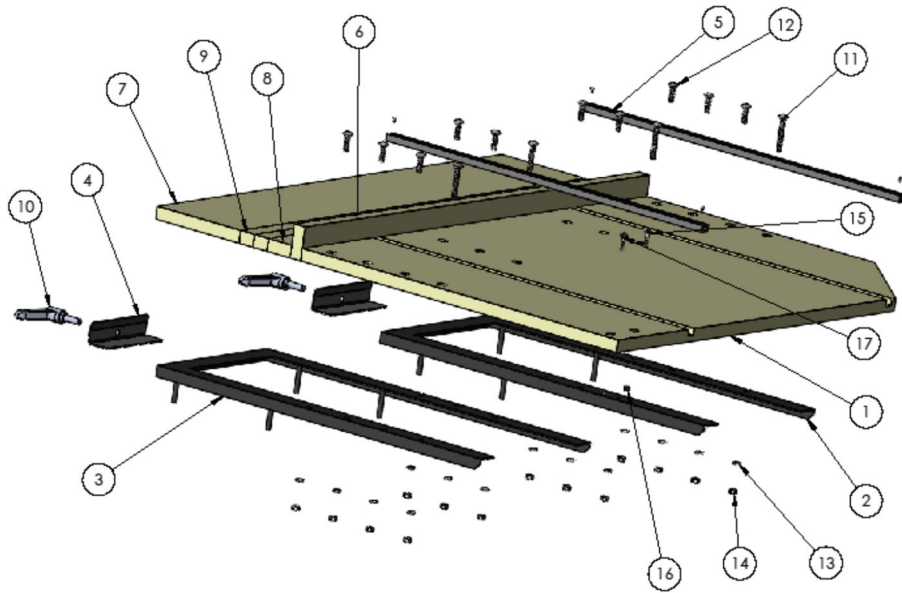

ITEM NO.	PART NUMBER	DESCRIPTION	QTY.
1	090516-06	SD Front Table Board, 34 x 49 Drilled and Slotted	1
2	090514-01	Cleat, Table 20\"/>	

800150-03

SD 16\"/>

Parts List and Ordering Instructions

Order only genuine replacement parts from your Original Saw Company Dealer.

When ordering parts be sure to include:

- Name of manufacturer—Original Saw Company
- Complete machine identification data found on name plate on front of frame
- Complete motor identification from motor name plate
- Quantity, part number and description of parts required
- Complete shipping and billing instructions

The Table Insert Kit is an optional accessory and not included as a standard item. Breakdown is provided for your convenience.

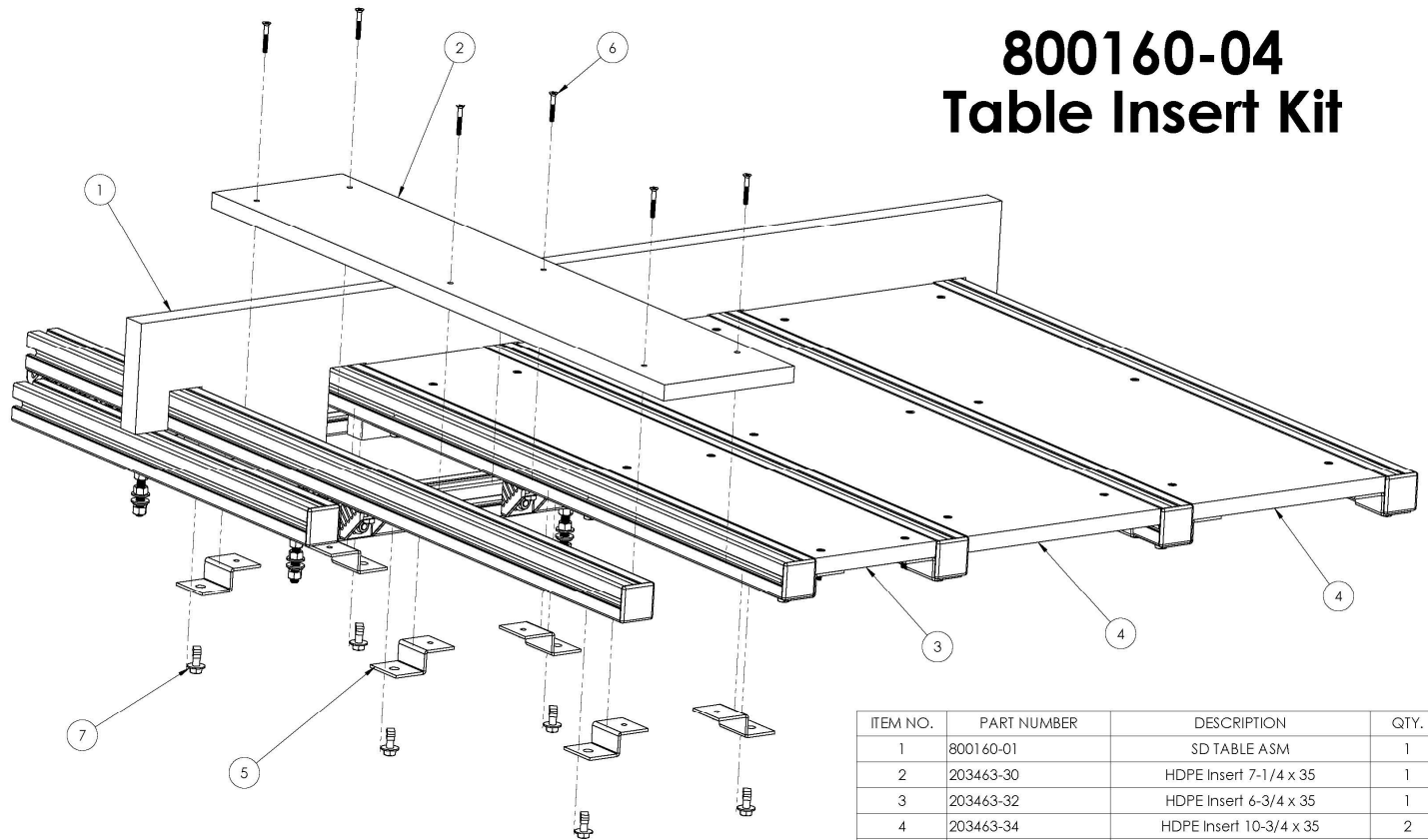

800160-04 Table Insert Kit

ITEM NO.	PART NUMBER	DESCRIPTION	QTY.
1	800160-01	SD TABLE ASM	1
2	203463-30	HDPE Insert 7-1/4 x 35	1
3	203463-32	HDPE Insert 6-3/4 x 35	1
4	203463-34	HDPE Insert 10-3/4 x 35	2
5	203464-58	Bracket-Mounting, HDPE Insert	24
6	082323	10-24 X 1 3/8 FLATHEAD SCREW	24
7	050112-01	GUSSET, 45mm	24

NOTE! This breakdown is effective for machines produced 2.01.2023 or after using 1/2" HDPE material.

Parts List and Ordering Instructions

Order only genuine replacement parts from your Original Saw Company Dealer.

When ordering parts be sure to include:

- Name of manufacturer—Original Saw Company
- Complete machine identification data found on name plate on front of frame
- Complete motor identification from motor name plate
- Quantity, part number and description of parts required
- Complete shipping and billing instructions

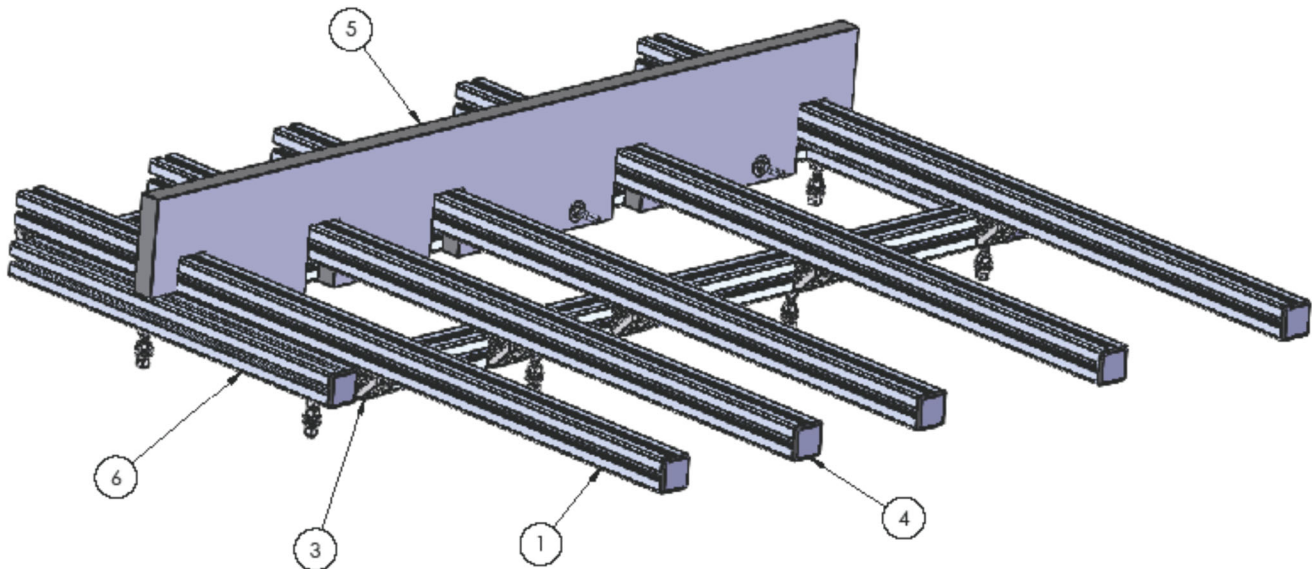

ITEM NO.	PART NUMBER	DESCRIPTION	QTY.	
1	050100-1170 (46)	45mm EXTRUSION	5	800160-01
1	050100-1270 (50)	45mm EXTRUSION	5	800160-03
3	50110.00	GUSSET, 45mm	10	
4	050114-00	Cap	7	
5	103721-25	SD table fence kit, HDPE	1	
6	090545-01	MC Rail Support Frame	1	

800160-01 (Med Arm)
800160-03 (Long Arm)
 SD 22" Table Assembly

Parts List and Ordering Instructions

Order only genuine replacement parts from your Original Saw Company Dealer.

When ordering parts be sure to include:

- Name of manufacturer—Original Saw Company
- Complete machine identification data found on name plate on front of frame
- Complete motor identification from motor name plate
- Quantity, part number and description of parts required
- Complete shipping and billing instructions

203462-15 Manual Clamp assembly

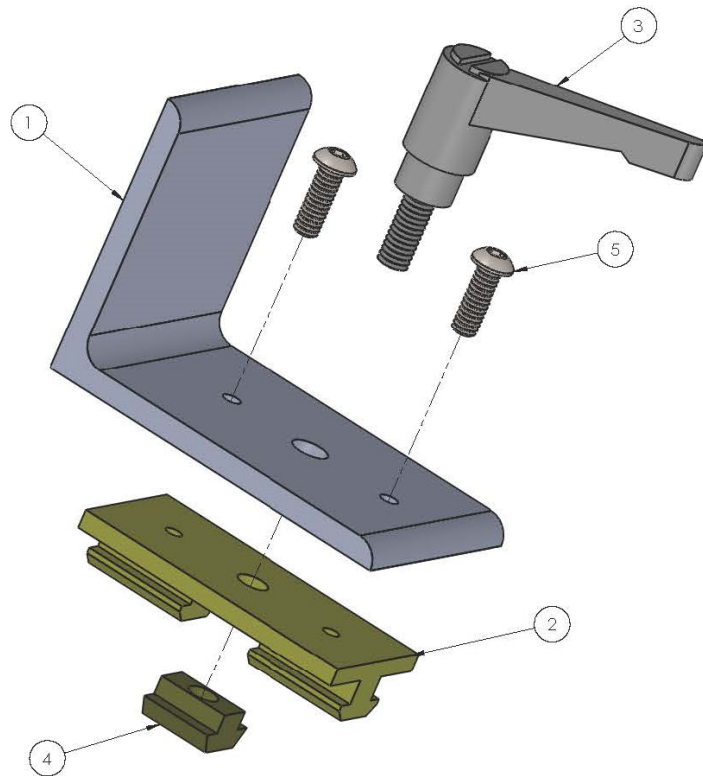

ITEM NO.	PART NUMBER	DESCRIPTION	QTY.
1	203462-51	Clamp section	1
2	900526-01	Slide - 10mm	1
3	900528-00	Locking Knob	1
4	900529-00	5/16 T-Nut	1
5	SBHCSCREW 0.25-20x0.75-HX-S		2

Parts List and Ordering Instructions

Order only genuine replacement parts from your Original Saw Company Dealer.

When ordering parts be sure to include:

- Name of manufacturer—Original Saw Company
- Complete machine identification data found on name plate on front of frame
- Complete motor identification from motor name plate
- Quantity, part number and description of parts required
- Complete shipping and billing instructions

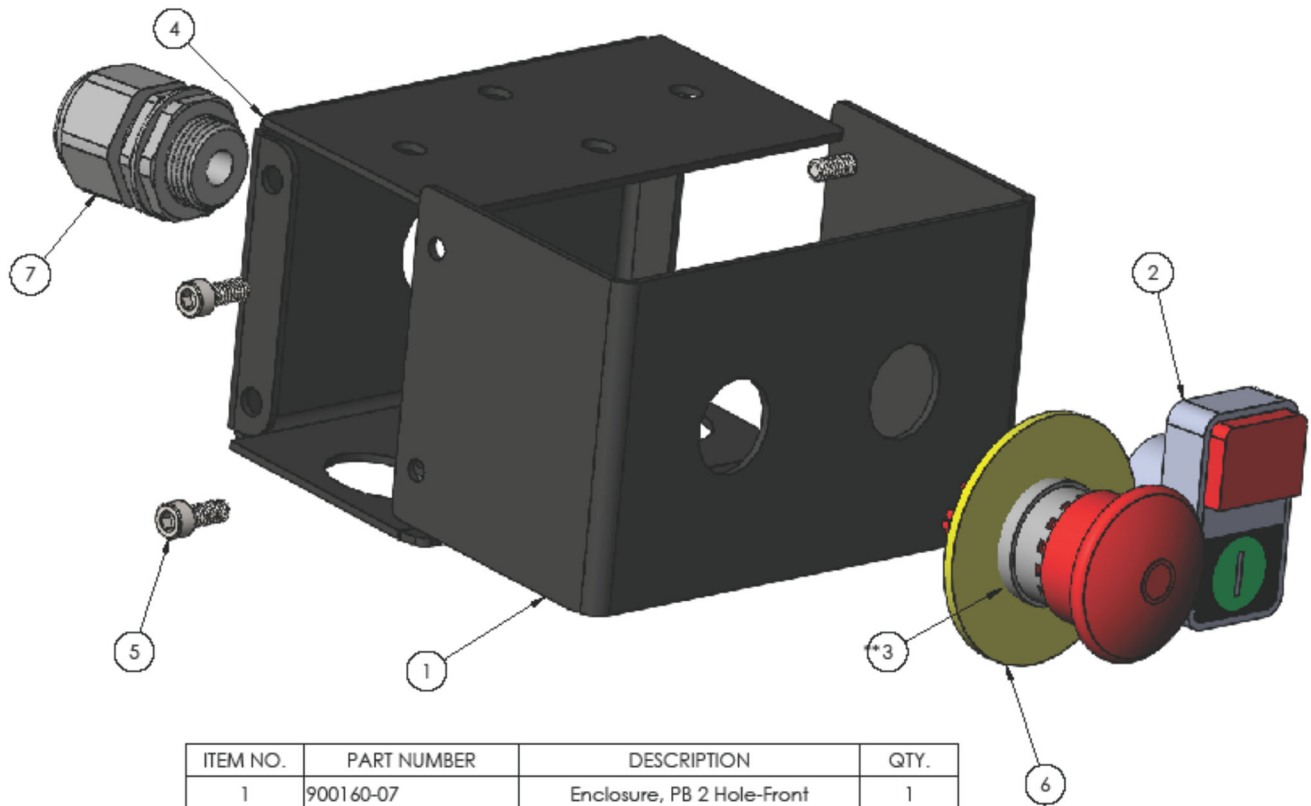

ITEM NO.	PART NUMBER	DESCRIPTION	QTY.
1	900160-07	Enclosure, PB 2 Hole-Front	1
2	900101-02	Switch Kit, Square Button	1
3	121270-02	E-Stop Push/Pull	1
4	900160-09	Enclosure, PB 2 Hole-Back	1
5	90128A220	SHCS, 10-24 X .50	4
6	121270-04	Legend- Yellow, E-Stop	1
7	69915K53	1/2" LTF	1

900160-05

Start / Stop, E-stop Station Assembly

Magnetic Starter Assembly

Magnetic starter with DC control circuit Super Duty Series

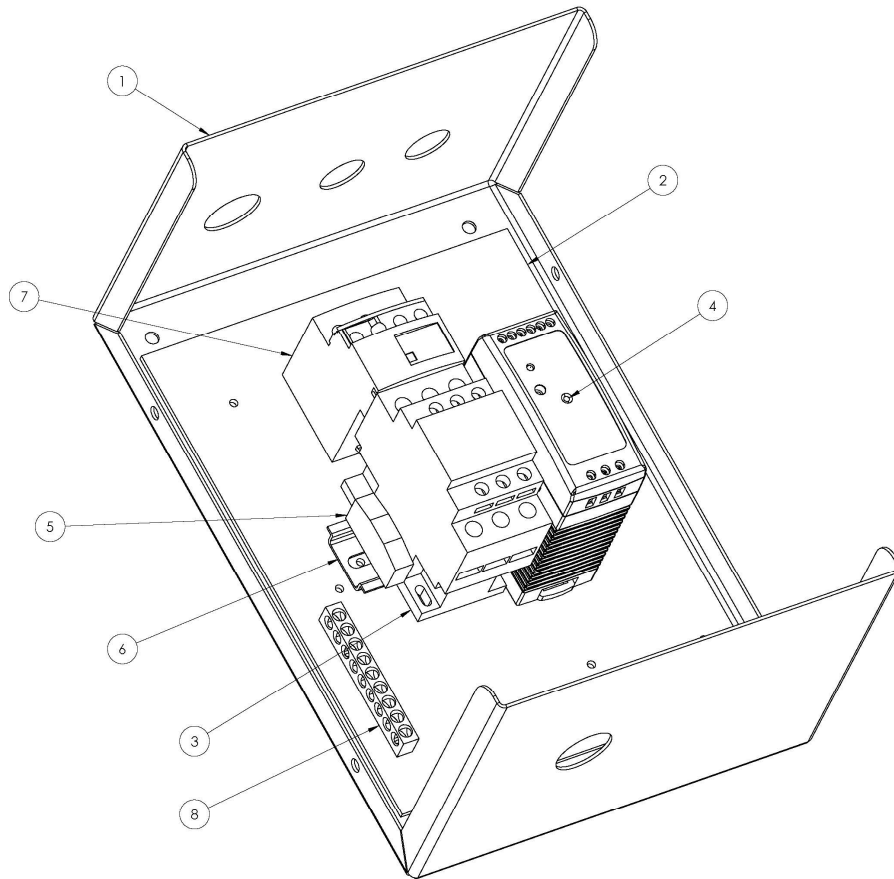

Index No.	Description	Qty
Entire assembly part numbers		
1	Enclosure (2 pcs back and door)	1
2	Subplate	1
3	Contactor	1
4	DC power supply	1
5	End stop (din rail)	2
6	Din Rail	1
7	Thermal overload	1
8	Ground lug	2

7.5hp 3 phase 230 v
700740-23-230
201474-28
201474-28s
122108-82-24vdc
122105-70-100/260
068720-16
hardware item
122110-87
081769-06

7.5hp 3 phase 460 v
700740-12-460
201474-28
201474-28s
122108-82-24vdc
122105-70-200/550
068720-16
hardware item
122110-85
081769-06

5hp 1 phase 220 v
700750-23-230
201474-28
201474-28s
122108-84-24vdc
122105-70-100/260
068720-16
hardware item
122110-87
081769-06

Motor Assembly

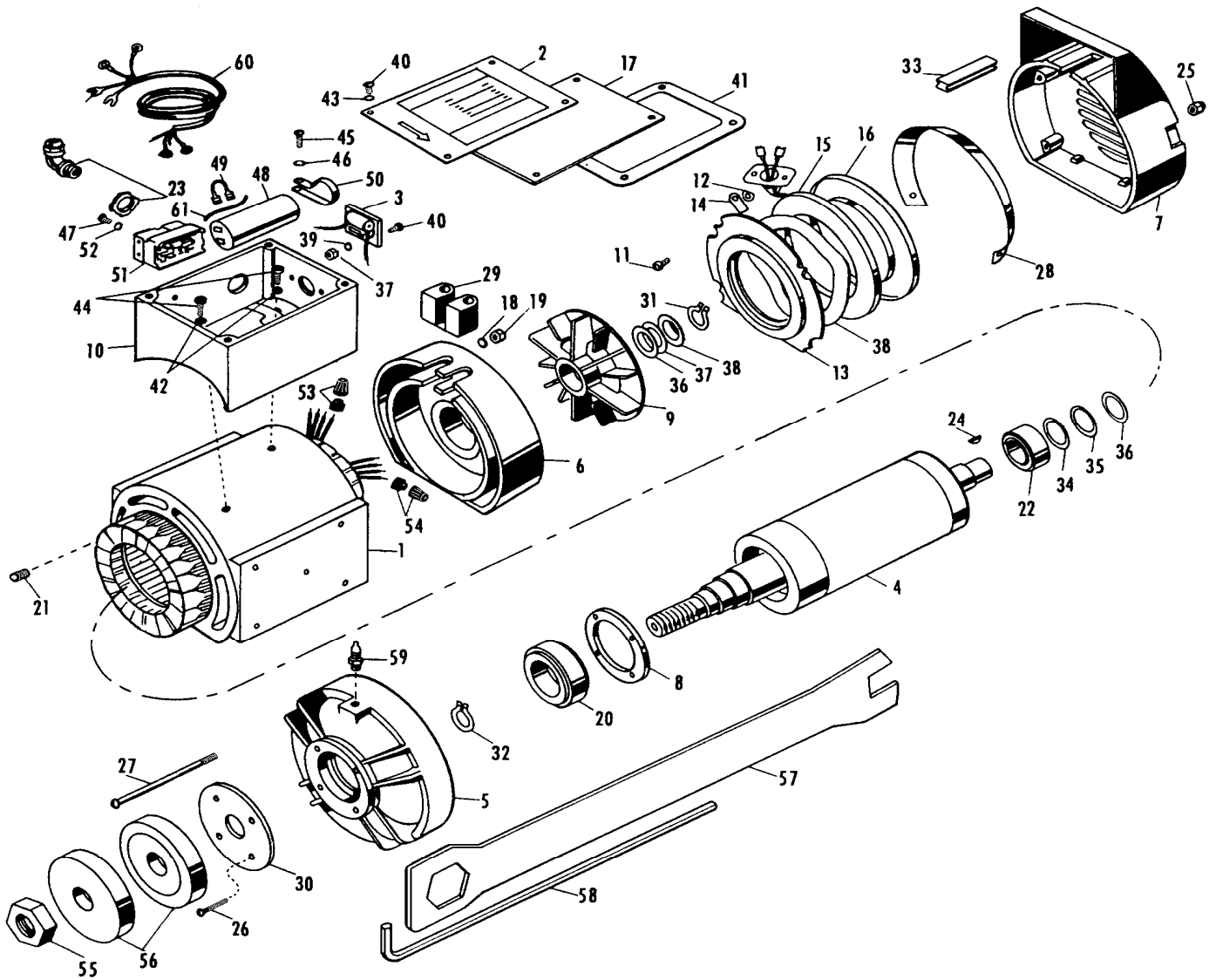

Motor Assembly

5 HP 1 PHASE 230 V - 123504

7.5 HP 3 PHASE 208/230/460 V - 123505-00

7.5 HP 3 PHASE 575 V - 123505-01

7.5 HP 3 PHASE 208/230/460 V - 123505-04-NB

7.5 HP 3 PHASE 575 V - 123505-05-NB

In-dex	5 HP 1 PH	7.5 HP 3 PH	Description	Qty	In-dex	5 HP 1 PH	7.5 HP 3 PH	Description	Qty
1	068554-56		Stators: 230 v 60 cycle	1	34	542004	542004	Shim Washer	AR
		068556-90			35	542252	542252	Shim Washer	AR
		068556-93			36	083799	083799	Shim Washer	AR
		068556-96			37	000407	000407	#8-32 Hex Nut	2
					38	083399	083399	Brake Spring	1
2	070266-00	070266-20	Motor Nameplate	1	39	000418	000418	#8 Lock washer	2
3	072222	072222	Brake Module	1	40	099262-10	099262-10	8-32 x 5/8 Screw	4/2
4	123503-01	123503-01	Rotor & Shaft 16"	1	41	067687	067687	Gasket	1
	123503-05	123503-05	Rotor & Shaft 20" & 22"						
5	083384	083384	Arbor End Bell	1	42	000417	000417	#10 Lock Washer	2
6	072227-01	072227-01	Fan End Bell	1	43	000418	000418	# 8 Lock Washer	4
7	083387	083387	Fan Housing	1	44	096994	096994	10-24 x 2 Phil Panhd	2
8	083419	083419	Bearing Cap	1	45	99249-05		10-24 x 3/8 Panhd Mach	1
9	096603	096603	SD Motor Fan & Liner	1	46	099384-07		5/16 Lock Washer	1
10	068293-02	068293-01	Conduit Box		47	099262-10		8-32 x 5/8 Screw	2
11	697162	697162	10-24x3/8 Sochd Cap Scrw	4	48	083382-01		Capacitor	1
12	000417	000417	10-24 Lock Washer	4	49	123484		Capacitor Lead	1
13	083396	083396	Brake Disk	1	50	068873		Capacitor Clamp	1
14	068532	068532	Retainer	4	51	068595-01		Relay	1
15	068593	068593-01	Brake Coil	1	52	000418		# 8 Lock Washer	2
16	070081	070081	Coil Housing	1	53	081733	081733	Wire Connector	4
17	067686	067686	Conduit Box Cover	1	54		081730	Wire Conn Brake Lead	6
18	084173	084173	1/4" Lockwasher	4	55	081433	081433	Arbor Nut	1
19	038738	038738	1/4-20 Hex Nut	4	56	101820-01	101820-01	4" Arbor Collar	2
20	123413	123413	Ball Bearing	1	57	301020-02	301020-02	Arbor Wrench	1
21	068703	068703	5/16-18 x 1/2 Soc Set Scrw	2	58	203511	203511	Wrench	1
22	123506	123506	Ball Bearing	1	59	103859	103859	Guard Stud 16" ONLY	1
23	068820-07	068820-07	3/4 NPT Nut	1	60			Motor Cables:	
24	026587	026587	Woodruff Key	1		096725		208/230V 1 Ph 60 Hz	1
25	066966	066966	1/4-20 Hex Cap Nut—Brass	4			096780	208-575V 3 Ph 50/60 Hz	1
26	082323	082323	10-24 x 1 3/8 Flathead Scr	4	61	123485		Capacitor Jumper	1
27	083388	083388	Tie Rod 16"	4					
	084647-01	084647-01	Tie Rod 20" & 22"						
28	083932	083932	Air Baffle	1					
29	072701	072701	Lead Grommet	1					
30	070786	070786	Cover Plate	1					
31	542253	542253	Retaining Ring	1					
32	541351	541351	Retaining Ring	1					
33	083898	083898	Slot Bushing—Rubber	1					

✦ Not used with NB Motors

★ Single Phase Only

Industrial Use Warranty Information

Your new Original Radial Arm Saw is precision manufactured under strict quality standards. In the unlikely event there is trouble with your machine, the Original Saw Company warrants the machine for the period of one year from the date of purchase. The warranty covers defects in materials and workmanship. We will cover the cost of the defective part and ground shipping. If a replacement part is sent under warranty the defective part must be returned to Original Saw Company or you will be charged for the replacement. The part must also be accompanied by a return goods authorization number. This number can be obtained by calling customer service at 1-800-733-4063. When the part is returned it may be repaired or replaced at our discretion. The part must be shipped prepaid to: The Original Saw Company, Attn. Warranty Replacement Counter, 465 Third Avenue SE, Britt, Iowa 50423.

IMPORTANT

IMPORTANT

IMPORTANT

To assure product reliability, repairs, maintenance and adjustments should be performed by Authorized Service Centers, always using genuine replacement parts.

For parts or service please contact Original Saw for the dealer nearest you.



465 Third Ave SE
P.O. Box 331
Britt, IA 50423
PH 800/733-4063 641-843-3868
FX 641 / 843-3869
E-mail customerservice@originalsaw.com
www.originalsaw.com