

Roller Table Extension -
parts breakdown and
assembly instructions

Covers part# 040030-00,
040030-01, 040030-02, 040031-
00, 040031-01, 040031-02

#	Part#	Description	Qty.
1	084179-14	Front rail (narrow)	1
2		roller & axle	8 / 15
	084185-00	Roller & axle zinc plated (18.25" wide)	
	084185-03	Roller & axle urethane coated steel	
	084184-01	Roller & axle zinc plated (11.25" wide)	
3	084179-16	Brace, roller table	3
	084179-07	Brace, for narrow roller	
4	084179-12	Rail, flanged rear	1
Hardware parts not shown:			
	096779-00	Carriage bolt, 5/16-18 x x.75	16
	099384-07	Nut, hex 5/16-18	16
	099370-04	Lock washer 5/16	16

Proudly Made in USA

Assembly instructions:

1. Attach the braces (index #3) using the included 5/16 carriage bolts. Pay special attention to line up the square holes to allow the bolts to pass through. Install by inserting the carriage bolt from the outside so the head is exposed in the formed channel. Tighten down by using the included 5/16 lock washers and the 5/16 hex nuts on the inside of the brace.

1. The rollers have a spring loaded axle on one side. To Starting at one end of the rail, insert the non-spring loaded end into a hex opening on one of the rails and then insert the other end by depressing the axle against its spring tension and insert into the opposing hex cut-out on the other rail. Install in every other hole for the units with 8 rollers or every hole on the units with 15 rollers.

1. To attach the leg to the frame simply insert the carriage bolt through the roller table rails and into the top of the leg; there should be 4 carriage bolts used for each leg set. Tighten the 5/16 lock washer and the 5/16 hex nut on the underside of the top edge of the leg set.

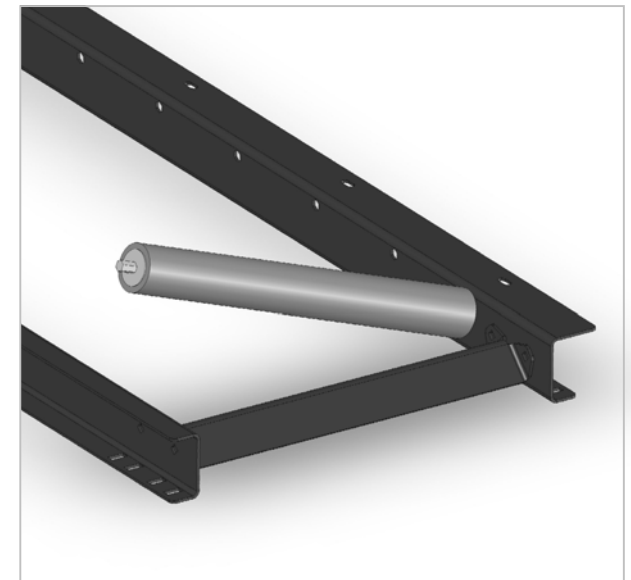
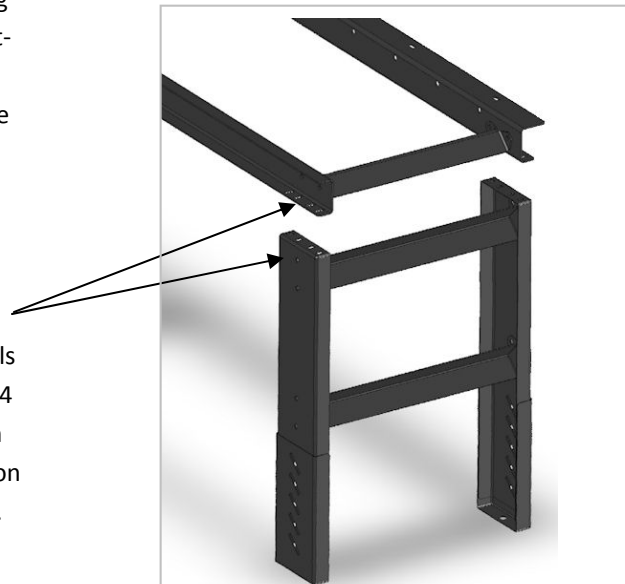
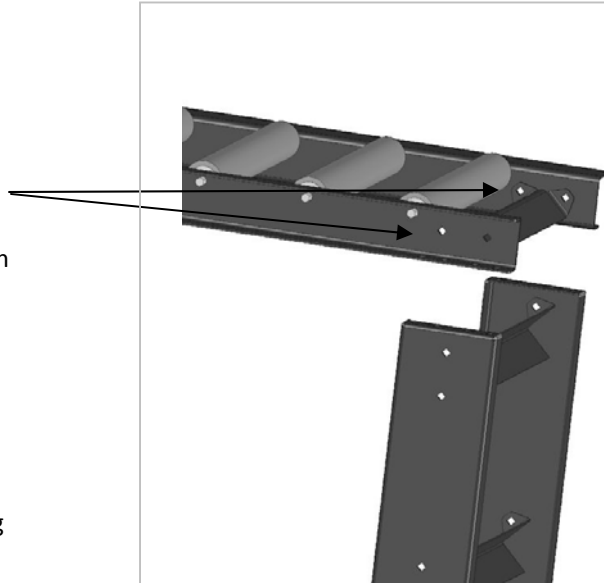



040029-00 / 040029-02

Adjustable Leg

Legs adjust from 31.9 to 28.2

Proudly Made in USA

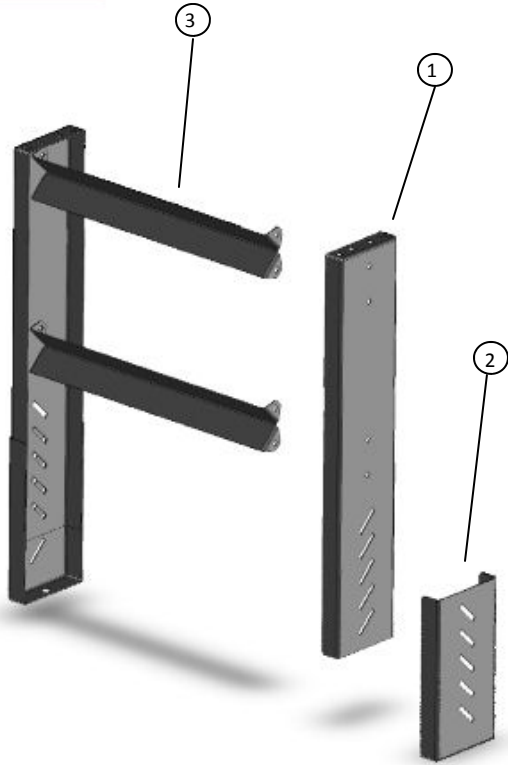

Assembly instructions:

1. Attach the adjustable feet with the included carriage bolts. Pay attention to install the heads outside and the lock washer and hex nut in the inside of the formed channel. Mount the adjustable feed at the lowest point in the adjustability range and both feet at the same height; this will make the final adjustment easier.

After the adjustable feet have been bolted on attach the braces (index#3) paying special attention to line up the square holes in the leg with the square hole in the brace. Insert the included carriage bolt (8 pieces) with the head to the outside and the lock washer and hex nut on the inside of the formed channel of the leg.

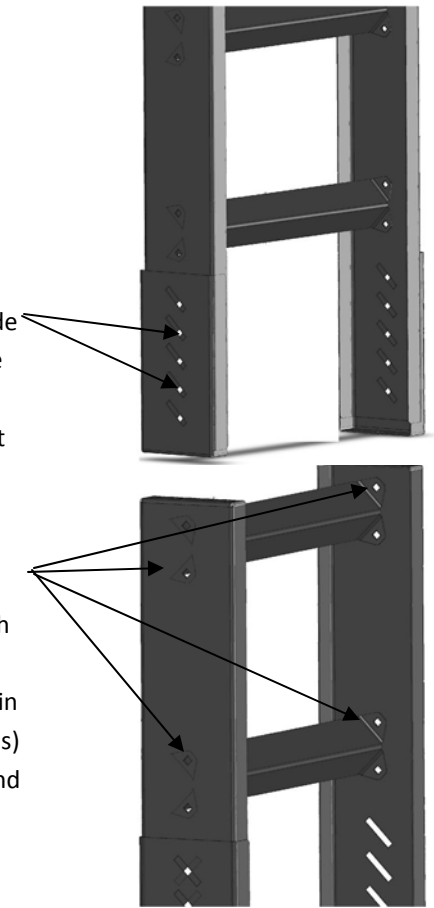

3. Adjusting the leg to the proper height will require assistance from another person. To adjust the leg to the proper height loosen the hex nuts on the inside of the adjustable foot, then lift the leg assembly to the proper height and tighten. (Note the each bolt layout will only allow a few inches of adjustment) If the foot needs to be moved past its range of motion the bolts may need to be repositioned to the next slot up or down to achieve the proper height.

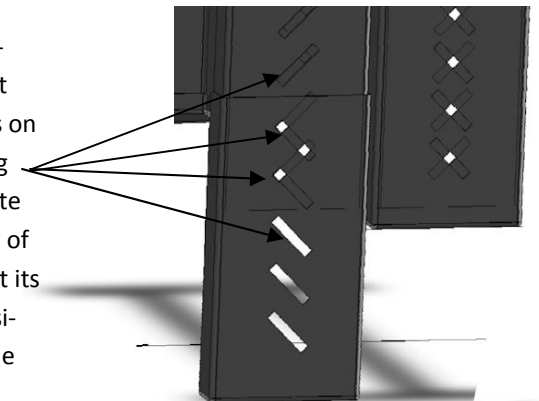

#	part#	description	qty
1	084179-02	Leg	2
2	084179-04	Foot, adjustable	2
3		Brace, leg	2
	084179-06	Brace, leg (20.4" wide assy # 040029-00)	
	084179-08	Brace, leg (10.9" wide assy # 040029-02)	
Hardware parts not shown:			
	096779-00	Carriage bolt, 5/16-18 x .75	16
	099384-07	Nut, hex 5/16-18	16
	099370-04	Lock washer 5/16	16